

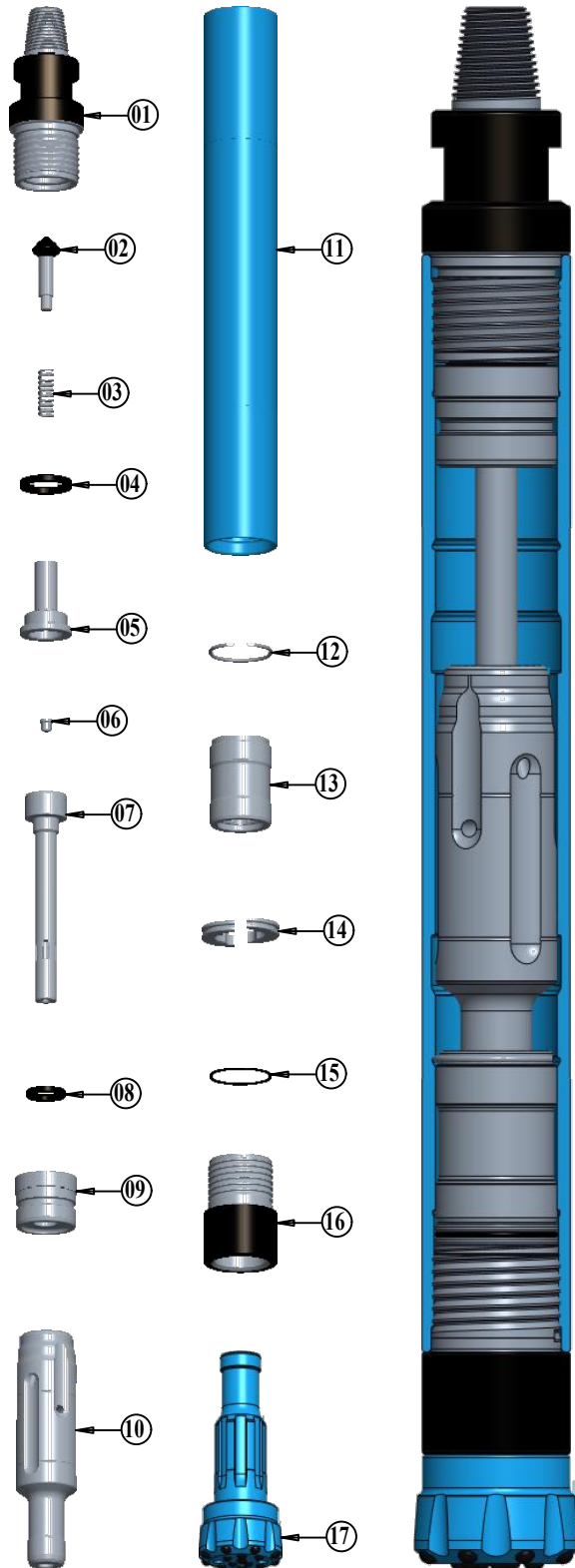

BULL ROCK DRILLS PRIVATE LIMITED

Write to us @ Plot. No. 34, IDA, Phase I, HCL Post, Cherlapally, Hyderabad-500051, Telangana, India.
Virtually introducing us @ <http://www.bullrockdrillspvtltd.co.in>

FORCE-45 DTH HAMMER EXPLODED & CROSS SECTIONAL VIEW



PART LIST

S.NO.	DESCRIPTION	DRW.NO.
01	HAMMER COUPLER	01-B-F45-01
02	DART	01-B-F45-02
03	SPRING	01-B-F45-03
04	BUFFER RING	01-B-F45-04
05	AIR DISTRIBUTOR	01-B-F45-05
06	C.T. BUFFER RING	01-B-F45-06
07	CHOKE	01-B-F45-07
08	CONTROL TUBE HOLDER	01-B-F45-08
09	CONTROL TUBE	01-B-F45-09
10	PISTON	01-B-F45-10
11	HAMMER CASE	01-B-F45-11
12	PISTON RETAINING RING	01-B-F45-12
13	GUIDE BUSH	01-B-F45-13
14	B.R.RING	01-B-F45-14
15	B.R.RING 'O' RING	01-B-F45-15
16	FRONT CHUCK	01-B-F45-16
17	BUTTON BIT	D-45
	HAMMER ASSEMBLY	01-B-F45-35-1P-2

SPECIFICATIONS

01	HAMMER TYPE	VALVELESS
02	HAMMER DIA	Ø108.0mm
03	CYLINDER BORE	Ø88.0mm
04	STROKE	95.0mm
05	LENGTH WITH OUT BIT	985.0mm
06	WEIGHT WITHOUT BIT	45.0 Kgs
07	END CONNECTION	2 3/8" API REG 5TPI
08	WRENCH FLAT SIZE	75.0mm
09	DRILLING RANGE	Ø121.0mm - Ø140.0mm
10	SUITABLE BUTTON BIT	D-45

AIR CONSUMPTION

PSI	150	200	250	300	350
CFM	170	262	366	482	607

NOTE:

TOP SUB TAPER THREAD CONNECTION SHALL BE PROVIDED AS PER CUSTOMER REQUIREMENT.

DUE TO CONTINUES PRODUCT DEVELOPMENT SPECIFICATIONS ARE SUBJECT TO CHANGE WITHOUT PRIOR NOTICE.