

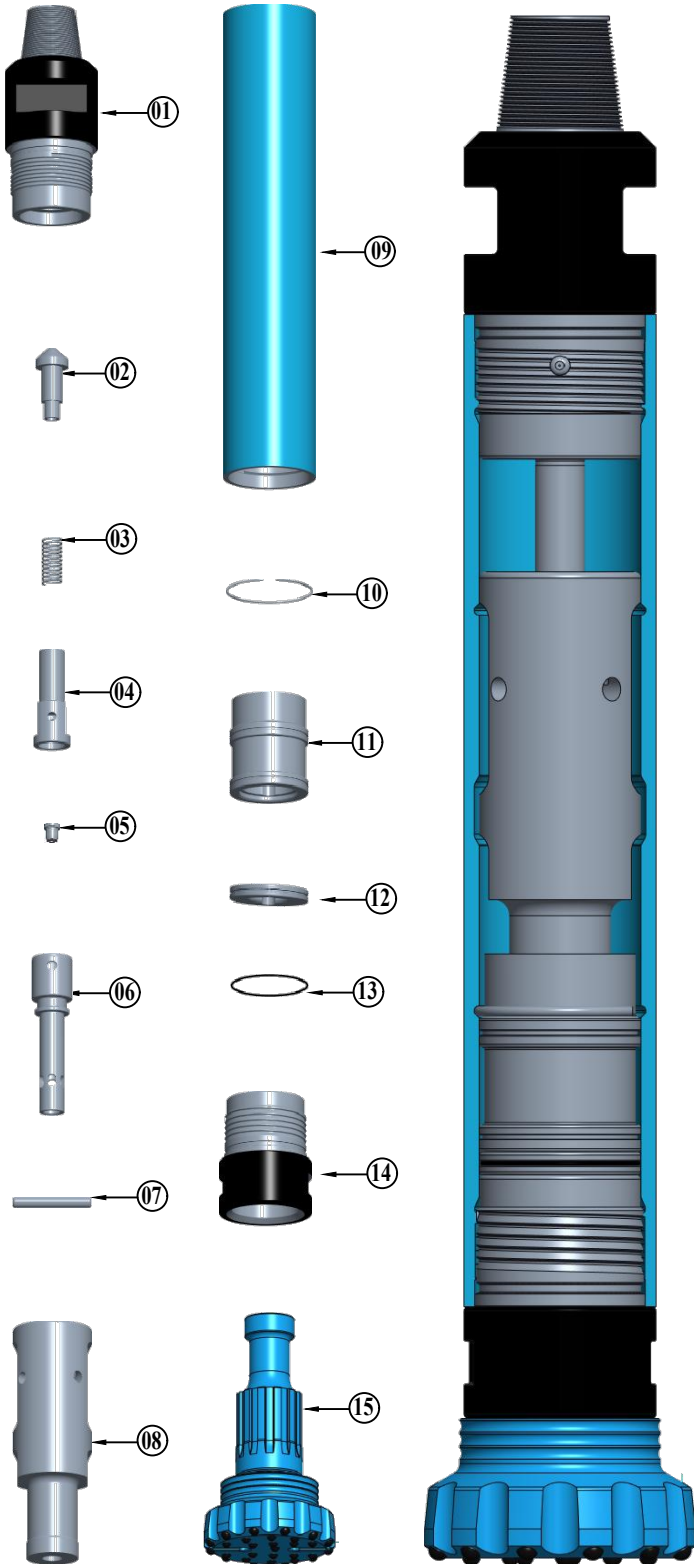

# BULL ROCK DRILLS PRIVATE LIMITED

Write to us @ Plot. No. 34, IDA, Phase I, HCL Post, Cherlapally, Hyderabad-500051, Telangana, India.  
Virtually introducing us @ <http://www.bullrockdrillspvtltd.co.in>

## FORCE-8 DTH HAMMER EXPLODED & CROSS SECTIONAL VIEW



### PART LIST

| SI.NO. | DESCRIPTION           | DRW.NO.         |
|--------|-----------------------|-----------------|
| 01     | HAMMER COUPLER        | 01-B-F8-01      |
| 02     | DART                  | 01-B-F8-02      |
| 03     | SPRING                | 01-B-F8-03      |
| 04     | AIR DISTRIBUTOR       | 01-B-F8-04      |
| 05     | CHOKE                 | 01-B-F8-05      |
| 06     | CONTROL TUBE          | 01-B-F8-06      |
| 07     | LOCKING PIN           | 01-B-F8-07      |
| 08     | PISTON                | 01-B-F8-08      |
| 09     | HAMMER CASE           | 01-B-F8-09      |
| 10     | PISTON RETAINING RING | 01-B-F8-10      |
| 11     | GUIDE BUSH            | 01-B-F8-11      |
| 12     | B.R.RING              | 01-B-F8-12      |
| 13     | B.R.RING 'O' RING     | 01-B-F8-13      |
| 14     | FRONT CHUCK           | 01-B-F8-14      |
| 15     | BUTTON BIT            | MISSION-80      |
|        | HAMMER ASSEMBLY       | 01-B-F8-28-7P-1 |

### SPECIFICATIONS

|    |                     |                     |
|----|---------------------|---------------------|
| 01 | HAMMER TYPE         | VALVELESS           |
| 02 | HAMMER DIA          | Ø178.0mm            |
| 03 | CYLINDER BORE       | Ø148.5mm            |
| 04 | STROKE              | 90.0mm              |
| 05 | LENGTH WITH OUT BIT | 1198.0mm            |
| 06 | WEIGHT WITHOUT BIT  | 160.0 Kgs(Approx.)  |
| 07 | END CONNECTION      | 4 1/2" API REG.     |
| 08 | WRENCH FLAT SIZE    | 115.0mm             |
| 09 | DRILLING RANGE      | Ø202.0mm - Ø254.0mm |
| 10 | SUITABLE BUTTON BIT | MISSION-80          |

Note: TOP SUB Taper Thread Connection shall be provided as per customer requirement.  
Due to continuous product development specifications are subject to change with out prior notice.