



# BULL ROCK DRILLS PRIVATE LIMITED

Write to us @ Plot. No. 34, IDA, Phase I, HCL Post, Cherlapally, Hyderabad-500051, Telangana, India.

Virtually introducing us @ <http://www.bullrockdrillspvtltd.co.in>

## HAWK-35 DTH HAMMER EXPLODED & CROSS SECTIONAL VIEW

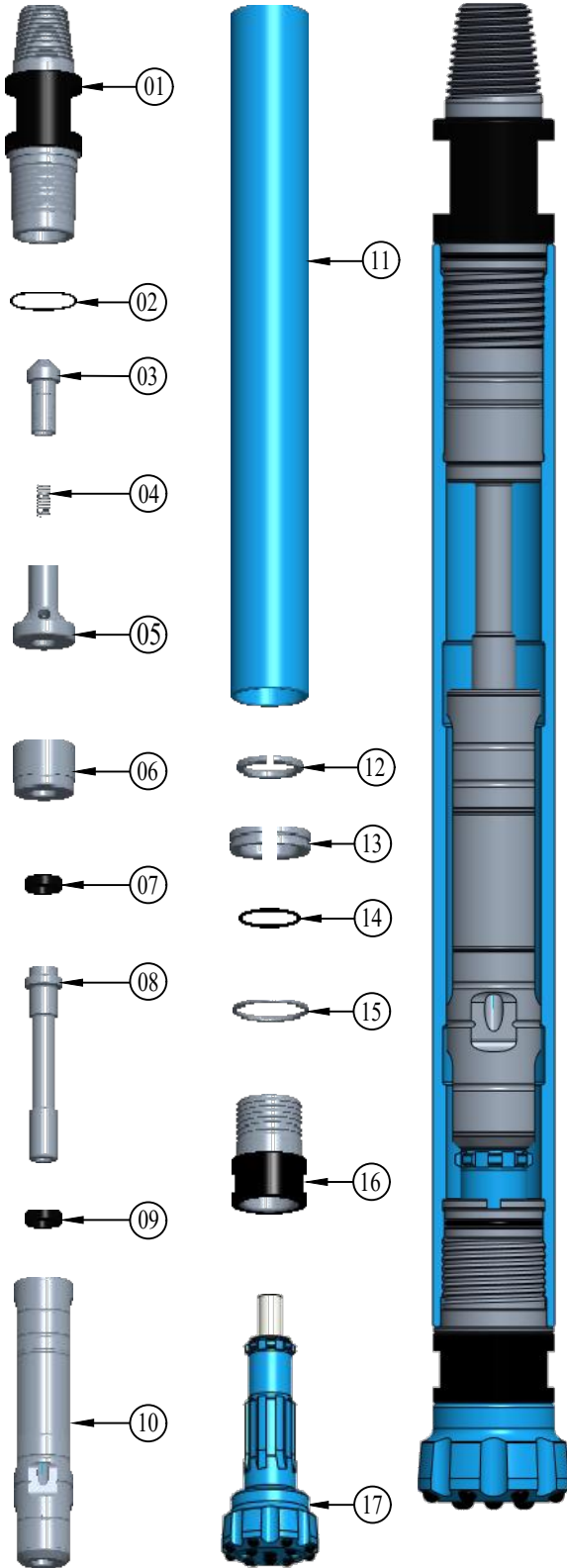

### PART LIST

SI.NO.	DESCRIPTION	DRW.NO.
01	HAMMER COUPLER	01-B-H35-01
02	COUPLER 'O' RING	01-B-H35-02
03	CHECK VALVE	01-B-H35-03
04	SPRING	01-B-H35-04
05	TOP VALVE	01-B-H35-05
06	TOPVALVE HOLDER	01-B-H35-06
07	BUFFER RING	01-B-H35-07
08	CONTEOL TUBE	01-B-H35-08
09	BUFFER RING	01-B-H35-09
10	PISTON	01-B-H35-10
11	HAMMER CASE	01-B-H35-11
12	CUT RING	01-B-H35-12
13	B.R.RING	01-B-H35-13
14	B.R.RING 'O' RING	01-B-H35-14
15	SPACER	01-B-H35-15
16	FRONT CHUCK	01-B-H35-16
17	BUTTON BIT	DHD-3.5
	HAMMER ASSEMBLY	01-B-H35-4-1P-2

### SPECIFICATIONS

01	HAMMER TYPE	VALVE TYPE
02	HAMMER DIA	Ø80.0mm
03	CYLINDER BORE	Ø62.25mm
04	STROKE	60.0mm
05	LENGTH WITH OUT BIT	866.0mm
06	WEIGHT WITHOUT BIT	24.5 Kgs
07	END CONNECTION	2 3/8" API REG. PIN
08	WRENCH FLAT SIZE	A/F 58.0 mm / 50.0 mm Wide
09	DRILLING RANGE	Ø90.0mm - Ø105.0mm
10	SUITABLE BUTTON BIT	DHD-3.5

### AIR CONSUMPTION

	100	150	200	250
PSI	100	150	200	250
CFM	130	195	260	325

### NOTE:

TOP SUB TAPER THREAD CONNECTION SHALL BE PROVIDED AS PER CUSTOMER REQUIREMENT.

DUE TO CONTINUES PRODUCT DEVELOPMENT SPECIFICATIONS ARE SUBJECT TO CHANGE WITHOUT PRIOR NOTICE.