

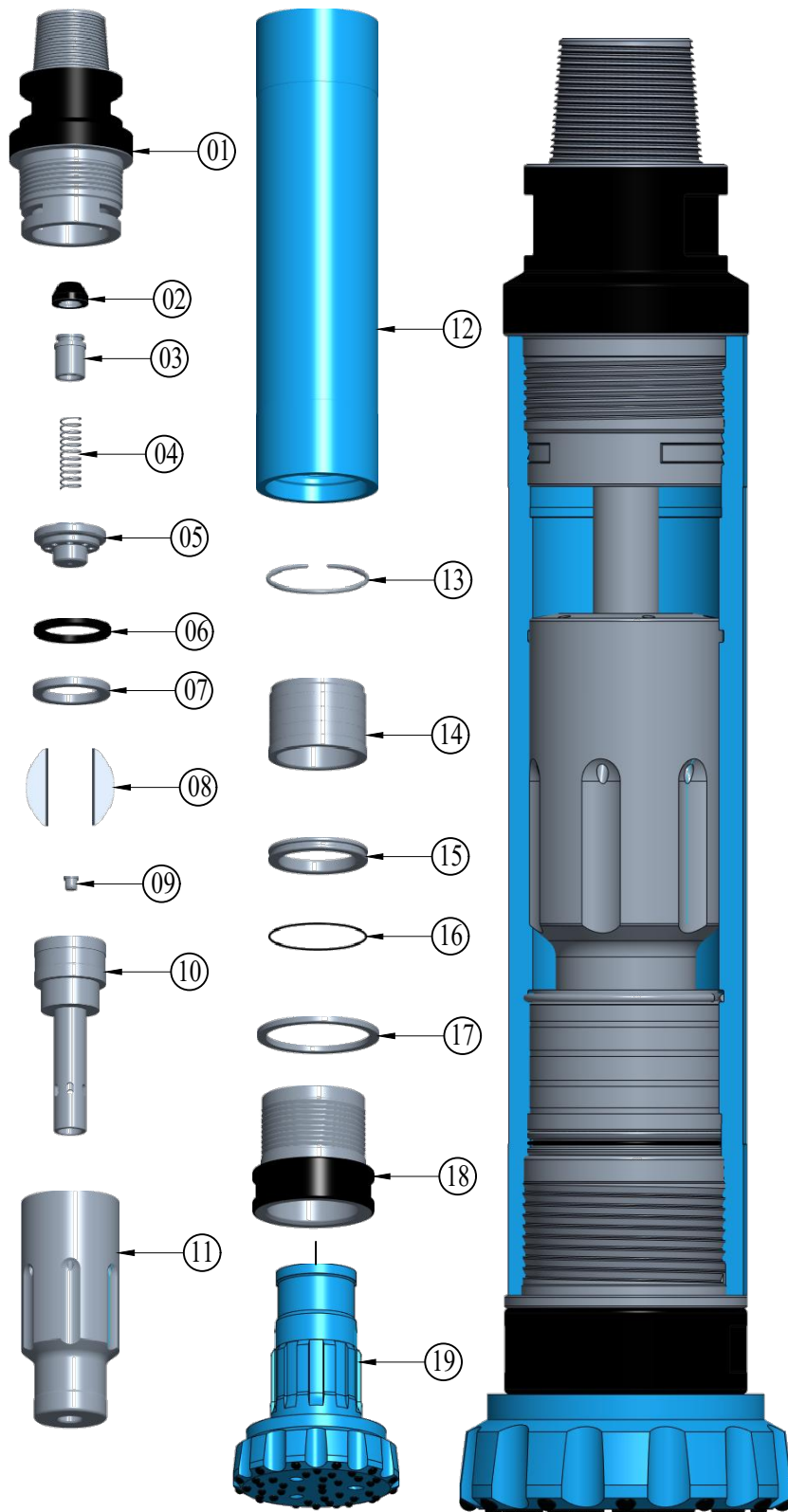

# BULL ROCK DRILLS PRIVATE LIMITED

Write to us @ Plot. No. 34, IDA, Phase I, HCL Post, Cherlapally, Hyderabad-500051, Telangana, India.  
 Virtually introducing us @ <http://www.bullrockdrillspvtltd.co.in>

## TURBO-10 DTH HAMMER EXPLODED & CROSS SECTIONAL VIEW



### PART LIST

SL. NO	DESCRIPTION	D.R.W NO
01	HAMMER COUPLER	01-B-T10-01
02	CHECK VALVE CAP	01-B-T10-02
03	CHECK VALVE	01-B-T10-03
04	SPRING	01-B-T10-04
05	AIR DISTRIBUTOR	01-B-T10-05
06	BUFFER RING	01-B-T10-06
07	METAL SPACER	01-B-T10-07
08	LOCK PLATE	01-B-T10-08
09	CHOKE	01-B-T10-09
10	CONTROL TUBE	01-B-T10-10
11	PISTON	01-B-T10-11
12	HAMMER CASE	01-B-T10-12
13	PISTON RETAINER RING	01-B-T10-13
14	GUIDE BUSH	01-B-T10-14
15	B.R.RING	01-B-T10-15
16	B.R.'O' RING	01-B-T10-16
17	FRONT CHUCK SPACER	01-B-T10-17
18	FRONT CHUCK	01-B-T10-18
19	BUTTON BIT	RK - III
	HAMMER ASSEMBLY	01-B-T10-32-7P-1

### SPECIFICATIONS

01	HAMMER TYPE	VALVELESS
02	HAMMER DIA	Ø198.0 mm
03	CYLINDER BORE	Ø157.50mm
04	STROKE	100.0mm
05	LENGTH WITH OUT BIT	1172.0mm
06	WEIGHT WITHOUT BIT	212.0 Kgs Approx.
07	END CONNECTION	4 ½ API Reg.Pin / D17 4TPI
08	WRENCH FLAT SIZE	A/F 138.0mm / 48.0 mm Wide
09	DRILLING RANGE	Ø254.0mm - Ø305.0mm
10	SUITABLE BUTTON BIT	RK-1

### NOTE:

TOP SUB TAPER THREAD CONNECTION SHALL BE PROVIDED AS PER CUSTOMER REQUIREMENT.  
 DUE TO CONTINUES PRODUCT DEVELOPMENT SPECIFICATIONS ARE SUBJECT TO CHANGE WITHOUT PRIOR NOTICE.