



# BULL ROCK DRILLS PRIVATE LIMITED

Write to us @ Plot. No. 34, IDA, Phase I, HCL Post, Cherlapally, Hyderabad-500051, Telangana, India.  
Virtually introducing us @ <http://www.bullrockdrillspvtltd.co.in>

**BULL ROCK**  
DRILLING TOOLS

## ROCKY FX-8 DTH HAMMER EXPLODED & CROSS SECTIONAL VIEW

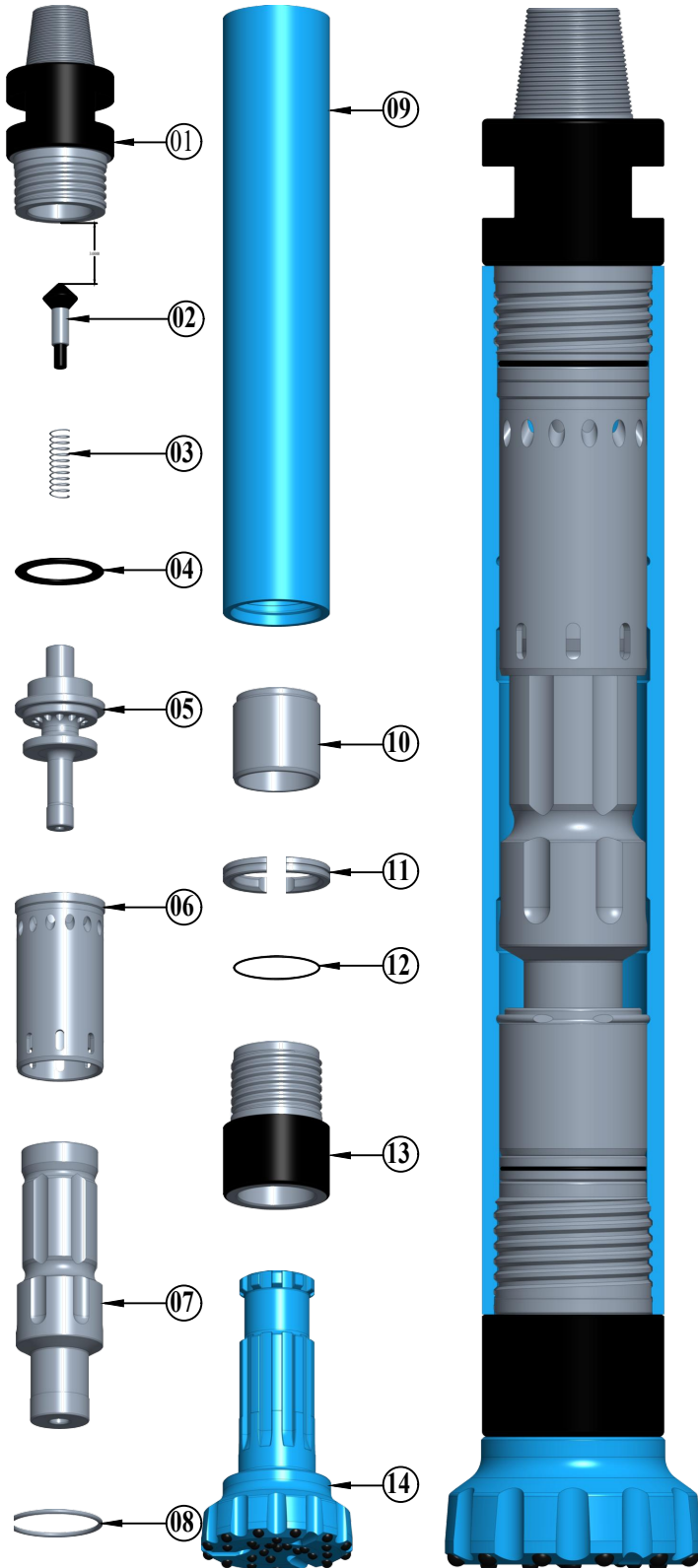

### PART LIST

SI.NO.	DESCRIPTION	PART.NO.
01	COUPLER	01-B-RF8-01
02	DART	01-B-RF8-02
03	SPRING	01-B-RF8-03
04	BUFFER RING	01-B-RF8-04
05	AIR DISTRIBUTER	01-B-RF8-05
06	LINER	01-B-RF8-06
07	PISTON	01-B-RF8-07
08	HAMMER CASE	01-B-RF8-08
09	PISTON RETAINER RING	01-B-RF8-09
10	BIT GUIDE	01-B-RF8-10
11	BIT RETAINER RING	01-B-RF8-11
12	BRR 'O' RING	01-B-RF8-12
13	FRONT CHUCK	01-B-RF8-13
14	BUTTON BIT	DHD 380 / QL-80 / SD-8
	HAMMER ASSEMBLY	01-B-RF8D-12-7P-2
	HAMMER ASSEMBLY	01-B-RF8Q-16-7P-2
	HAMMER ASSEMBLY	01-B-RF8S-21-7P-2

### SPECIFICATIONS

01	HAMMER TYPE	VALVELESS
02	HAMMER DIA	Ø178.0 mm
03	CYLINDER BORE	Ø144.0mm
04	STROKE	Ø90.0mm
05	LENGTH WITH OUT BIT	1235.0mm
06	WEIGHT WITH OUT BIT	172 Kgs (Approx.)
07	END CONNECTION	4 ½" API REG 5TPI
08	WRENCH FLAT SIZE	115.0 mm
09	DRILLING RANGE	Ø202.0mm - Ø254.0mm
10	SUITABLE BUTTON BIT	DHD 380 / QL-80 / SD-8 (With Out Foot Valve)

### AIR CONSUMPTION

PSI	150	200	250	300	350
CFM	300	450	700	900	1050

NOTE:  
TOP SUB TAPER THREAD CONNECTION SHALL BE PROVIDED AS PER AS PER CUSTOMER REQUIREMENT.  
DUE TO CONTINUES PRODUCT DEVELOPMENT SPECIFICATIONS ARE SUBJECT TO CHANGE WITHOUT PRIOR NOTICE.